

LED Combination Lamps

BR205 SERIES



FEATURES

- Compact marine LED combination lamp
- 12V DC input & low current draw
- Brighter than conventional incandescent systems
- 100,000 hour LED life span with solid state technology
- Maintenance free
- High impact ABS housing & polycarbonate lens
- Water and dust proof (submersible)
- Pre-wired with 300mm of sheathed tinned copper cable
- Available in a DIY twin pack
- Simple surface mount design
- ADR/ECE approved for all functions



ROADVISION's BR205 Series LED rear combination lamps are the complete 12V marine trailer solution! Featuring Stop/Tail, Indicator & Reflector functions, they are designed specifically for marine trailer applications. The smallest of the BR Series marine trailer lamps, they are designed for budget conscious 12V DC applications where space is at a premium, delivering the durability of maintenance free LED technology and greater visibility providing increased safety. Roadvision's BR205 Series combination lamps produce more light output than incandescent lamps whilst drawing a fraction of the current. Couple this with unbreakable polycarbonate lenses and an extremely tough housing manufactured from high impact ABS, these lamps are dust & water proof and totally maintenance free with a lifespan rated at 100,000hrs. With ROADVISION it's FIT & FORGET.

PART NUMBERS



BR205LR

Combination Lamp Kit LED 12V 162x80mm Oval Stop/Tail/Ind/Ref Twin Pack Submersible



SPECIFICATIONS

	BR205LR
Current Draw Amps	Ind - 0.1A, S/T - 0.1/0.05A @ 13.8V
Dimensions	162x80x19mm
Mounting Depth	Surface Mount
Mounting Hole / Cut Out	100mm Stud Centres
Lamp Functions	Stop/Tail/Indicator/Reflector
Number of LED's	Indicator - 7 LED's, Stop/Tail - 7 LED's
Cable Length	300mm Sheathed
Approvals	Ind - CRN 46077, Stop - CRN 46100, Tail - CRN 46139, Ref - CRN 46123
Note	Twin Pack

LINE DIAGRAM

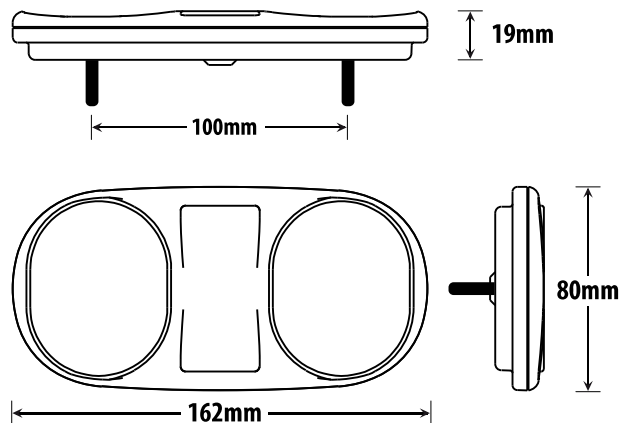

SPARE PARTS & ACCESSORIES



BR12

LED Load Resistor 12V