

LED Combination Lamps

BR208 SERIES



FEATURES

- Compact LED combination lamp
- 12V DC input & low current draw
- 100,000 hour rated LED lifespan with solid state technology
- Water & dust proof (submersible)
- Sealed polycarbonate lens & housing
- Integrated reflector & optional licence plate lamp
- Pre-wired with 300mm sheathed tinned copper cable
- Easy surface mount stainless steel twin stud installation
- Maintenance free
- ADR/ECE approved for all functions



ROADVISION's BR208 Series LED rear combination lamps tick all the boxes! A simple DIY trailer lighting kit designed for the budget conscious consumer, delivering the durability of maintenance free LED technology and greater visibility providing increased safety. Roadvision's BR208 Series combination lamps produce more light output than incandescent lamps whilst drawing a fraction of the current. Constructed with durable polycarbonate lenses and housings, these lamps are dust & water proof and totally maintenance free with a lifespan rated at 100,000hrs. Fitment is also made easy with integrated twin mounting studs and stainless steel hardware. With ROADVISION it's FIT & FORGET.

PART NUMBERS



BR208LR
Combination Lamp Kit LED 12V 100mm Square Stop/Tail/Ind/Ref Twin Pack



BR208LRNP
Combination Lamp Kit LED 12V 100mm Square Stop/Tail/Ind/Ref Twin Pack with Licence



EL208
Combination Lamp LED 12V 100mm Square Stop/Tail/Ind/Ref



SPECIFICATIONS

	BR/EL208
Current Draw Amps	Ind - 0.1A, S/T - 0.1/0.02A @ 13.8V
Dimensions	100x100x21mm/37mm (Licence/MV)
Mounting Depth	Surface Mount
Mounting Hole / Cut Out	70mm Stud Centres
Lamp Functions	Stop/Tail/Indicator/Reflector (Lic)
Number of LED's	Indicator - 5 LED's, Stop/Tail - 5 LED's
Cable Length	300mm Sheathed
Approvals	Ind - E4-6R-0116003, S/T - E4-7R-0216003, Ref - E4-3R-0216003 Lic - TBA

LINE DIAGRAM

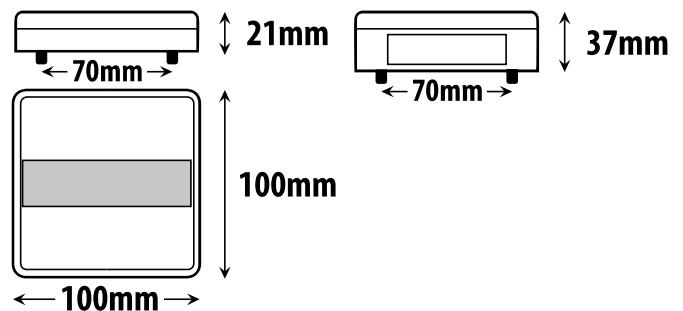

SPARE PARTS & ACCESSORIES

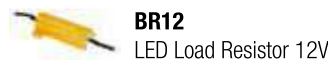

LED Combination Lamps



FEATURES

- Compact LED combination lamp
- 10-30V DC input & low current draw
- 100,000 hour rated LED lifespan with solid state technology
- Water & dust proof (submersible)
- Sealed polycarbonate lens & housing
- Integrated reflector & optional licence plate lamp
- Pre-wired with 300mm sheathed tinned copper cable
- Easy surface mount stainless steel twin stud installation
- Maintenance free
- ADR/ECE approved for all functions



ROADVISION's BR208 Series LED rear combination lamps tick all the boxes! Simple DIY trailer lights, now available in multi-volt input and designed for the budget conscious consumer they deliver the durability of maintenance free LED technology. Roadvision's BR208 Series combination lamps produce more light output than incandescent lamps whilst drawing a fraction of the current. Constructed with durable polycarbonate lenses and housings, these lamps are dust & water proof and totally maintenance free with a lifespan rated at 100,000hrs. Fitment is also made easy with integrated twin mounting studs and stainless steel hardware. With ROADVISION it's FIT & FORGET.

PART NUMBERS



BR208MV

Combination Lamp LED 10-30V 100mm Square Stop/Tail/Ind/Ref



BR208NPMV

Combination Lamp LED 10-30V 100mm Square Stop/Tail/Ind/Ref with Licence

SPECIFICATIONS

	BR208MV	BR208NPMV
Current Draw Amps	Ind - 0.1A, S/T - 0.1/0.02A @ 13.8V	Ind - 0.1A, S/T - 0.1/0.02A @ 13.8V
Dimensions	100x100x37mm	100x100x37mm
Mounting Depth	Surface Mount	Surface Mount
Mounting Hole / Cut Out	70mm Stud Centres	70mm Stud Centres
Lamp Functions	Stop/Tail/Indicator/ Reflector	Stop/Tail/Indicator/ Reflector
Number of LED's	Indicator - 5 LED's, Stop/Tail - 5 LED's	Indicator - 5 LED's, Stop/Tail - 5 LED's, Lic - 4 LED's
Cable Length	300mm Sheathed	300mm Sheathed
Approvals	TBA	TBA

LINE DIAGRAM

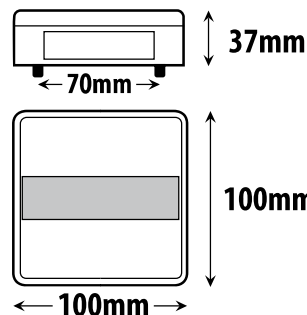

SPARE PARTS & ACCESSORIES

