

# LED Combination Lamps

BR200 SERIES

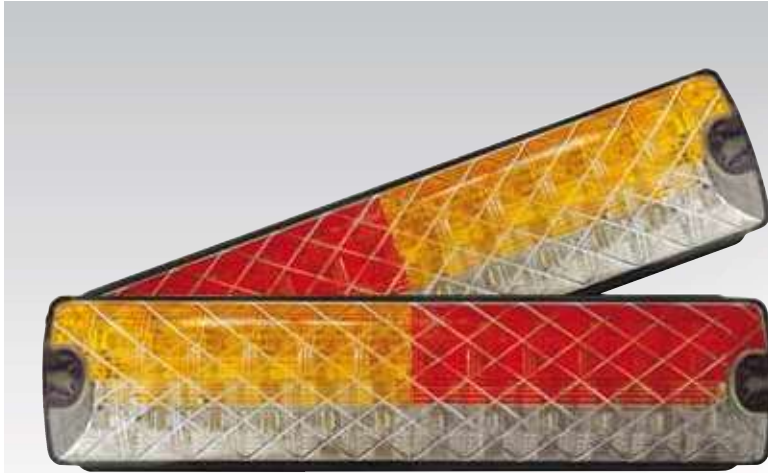

## FEATURES

- Compact slimline LED combination lamp
- Multi-volt 10-30V DC input & low current draw
- Brighter than conventional incandescent systems
- 100,000 hour LED life span with solid state technology
- Maintenance free
- Sealed polycarbonate lens & housing
- Water and dust proof
- Supplied pre-wired with 300mm LEDLink Connector
- Available in twin pack with integrated reverse function
- Simple surface mount design
- ADR/ECE approved for all functions



ROADVISION's BR200 Series LED rear combination lamps are a versatile slimline solution! Featuring Stop/Tail & Indicator or Stop/Tail, Indicator & Reverse functions all in a super slim line package, the BR200 Series are a simple DIY trailer lighting solution. Designed for applications where space is at a premium, they deliver the durability of maintenance free LED technology and greater visibility providing increased safety. BR200's are designed to be easily attached to horizontal or vertical mounting surfaces with a simple surface mount design. Roadvision's BR200 Series combination lamps produce more light output than incandescent lamps whilst drawing a fraction of the current. Constructed with durable polycarbonate lenses and housings, these lamps are dust & water proof and totally maintenance free with a lifespan rated at 100,000hrs. With ROADVISION it's FIT & FORGET.

## PART NUMBERS

 **BR200AR**  
Combination Lamp LED 10-30V 204x40mm Rect Strip Stop/Tail/Ind



 **BR200LRARW**  
Combination Lamp Kit LED 10-30V 204x40mm Rect Strip Stop/Tail/Ind/Rev Twin Pack



## SPECIFICATIONS

|                         | BR/EL200AR   | BR200LRARW  |
|-------------------------|--|---|
| Current Draw Amps       | Ind - 0.2A, S/T - 0.2/0.05A @ 13.8V                    | Ind - 0.05A, S/T - 0.05/0.05A, Rev 0.1A@ 13.8V                    |
| Dimensions              | 205x40x28mm  | 195x50x32mm   |
| Mounting Depth          | Surface Mount  | Surface Mount   |
| Mounting Hole / Cut Out | 160mm  | 175mm   |
| Lamp Functions          | Stop/Tail/Indicator                                    | Stop/Tail/Indicator/Reverse                                       |
| Number of LED's         | Indicator - 12 LED's, Stop/Tail 12 LED's               | Indicator - 6 LED's, Stop/Tail 6 LED's, Reverse - 12 LED's        |
| Cable Length            | 300mm LEDLink Connector                                | 300mm LEDLink Connector   |
| Approvals               | Ind - CRN 46095, Stop - CRN 46094,<br>Tail - CRN 46093 | Ind - E4-6R-0115710, S/T - E4-7R-0215710,<br>Rev - E4-23R-0015710 |

## BR200 SERIES AVAILABLE IN TWO MODELS



### BR200AR

Functions: Stop/Tail & Indicator  
 Dimensions: 205 x 40mm  
 Left or Right Hand

### BR200LRARW

Functions: Stop/Tail/Indicator & Reverse  
 Dimensions: 195 x 50mm  
 Twin Pack – Left & Right Hand

### SPARE PARTS & ACCESSORIES



**BR12**  
 LED Load Resistor 12V



**BR24**  
 LED Load Resistor 24V

### LINE DIAGRAM

#### BR200AR

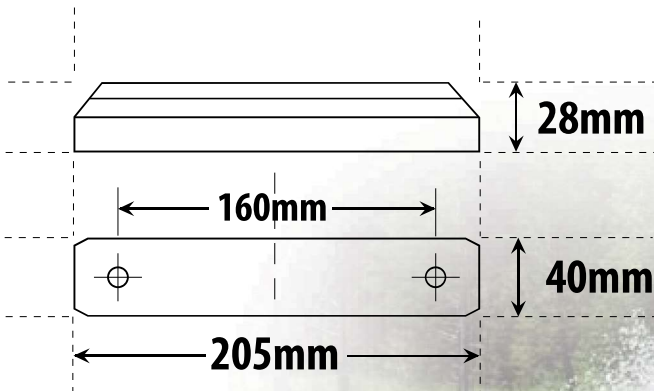

#### BR200LRARW

